

ENGINE

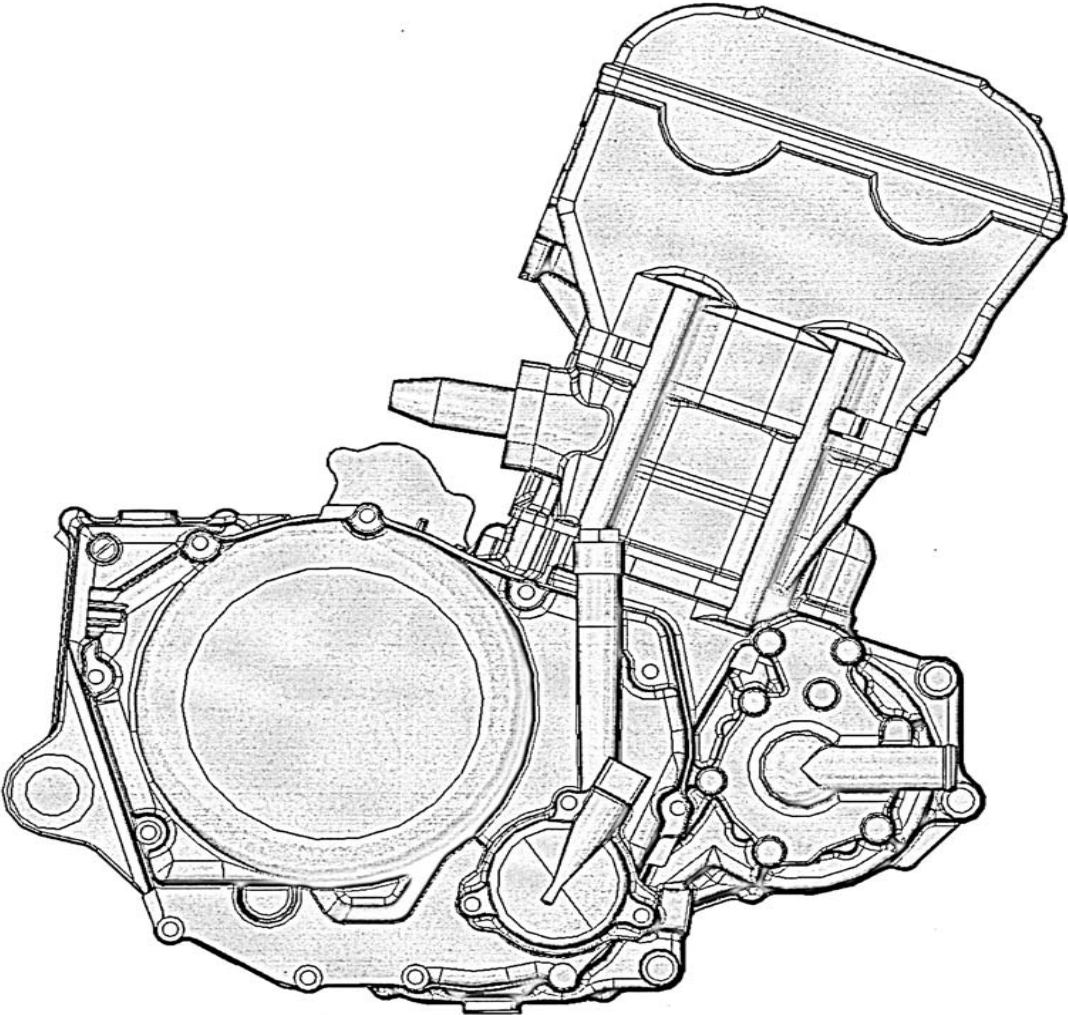

D1033-011

**ENGINE**

<b>Model</b>	<b>Item</b>	<b>Part no</b>	<b>Description</b>	<b>Specification</b>	<b>Q'ty of Usage</b>	<b>Note</b>
	01	E140000-01	E14 ENGINE	450C.C.	1	

FENDER · SEAT

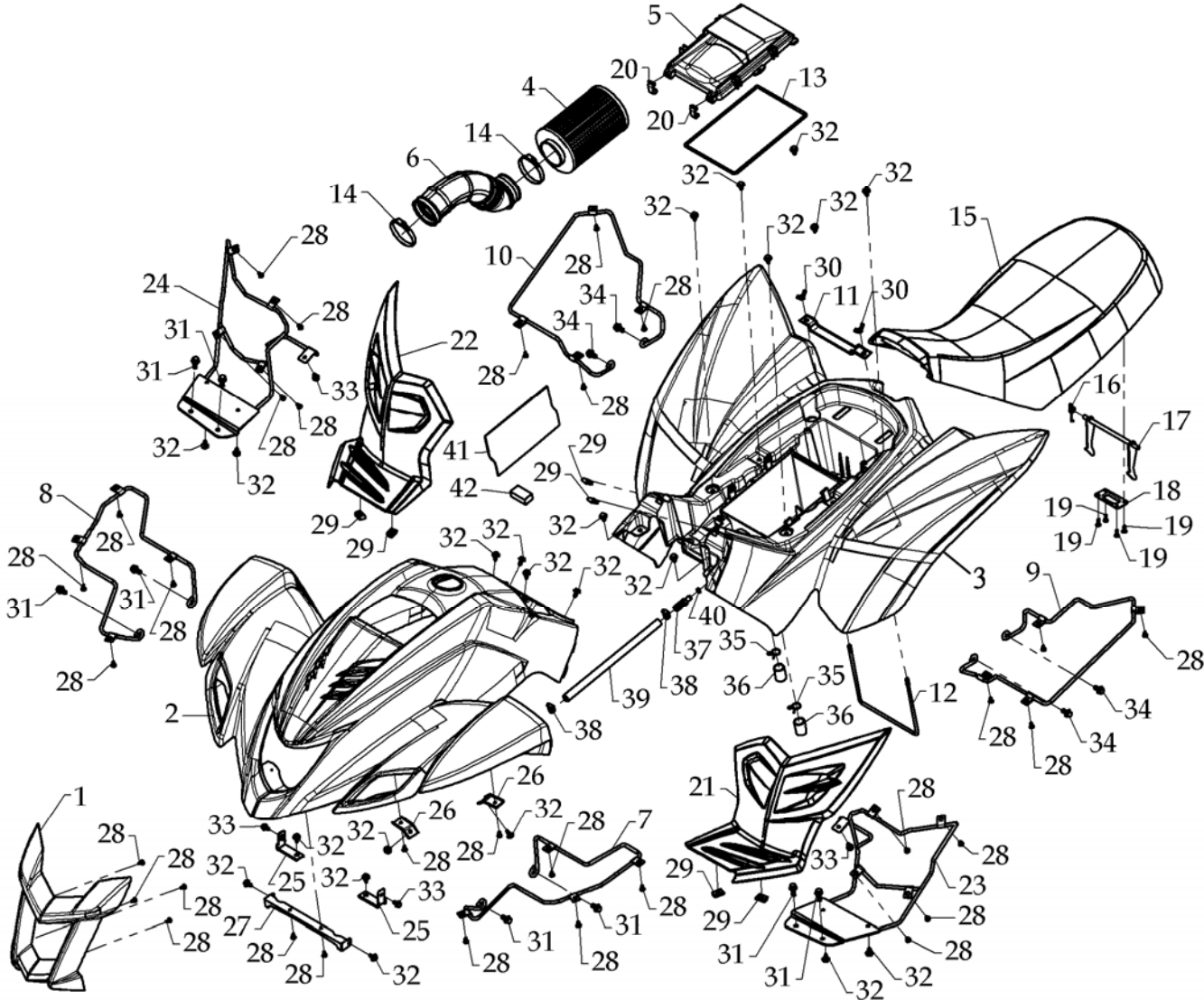

D1033-021

## FENDER、SEAT

Model	Item	Part no	Description	Specification	Q'ty of Usage	Note
	01	F200001-15	BUMPER		1	
	02	F200002-98	FRONT FENDER		1	
	03	F200003-98	REAR FENDER		1	
	04	F200005-00	CORE,AIR CLEANER		1	
	05	F200006-00	COVER,AIR CLEANER		1	
	06	F200007-00	INTAKE DUCT,CARBURETOR		1	
	07	F200008-50	BRACKET,FRONT FENDER	LEFT SIDE	1	
	08	F200009-50	BRACKET,FRONT FENDER	RIGHT SIDE	1	
	09	F200010-50	BRACKET,REAR FENDER	LEFT SIDE	1	
	10	F200011-50	BRACKET,REAR FENDER	RIGHT SIDE	1	
	11	F200015-50	FIXTURE,BATTERY		1	
	12	F200016-42	BRACKET,BATTERY		1	
	13	F200019-00	SEAL,AIR CLEANER		1	
	14	A220029-00	CLAMP	Ø80×9mm	2	
	15	F150089A98	SEAT		1	
	16	A110043-00	TWIST SPRING	Ø2	1	
	17	F150149-42	HOOK		1	
	18	F030021-42	PLATE		1	
	19	A130005-43	TAPPING SCREW	5mm×16L	4	
	20	F140136-00	CLIP		2	
	21	F150096A15	LEFT FOOT BOARD		1	
	22	F150097A15	RIGHT FOOT BOARD		1	
	23	F150221-50	FOOT BOARD BRACKET	LEFT SIDE	1	
	24	F150222-50	FOOT BOARD BRACKET	RIGHT SIDE	1	
	25	A230077A50	BRACKET,FRONT FENDER	FRONT	2	
	26	A230078A50	BRACKET,FRONT FENDER	REAR	2	
	27	A230084-50	BRACKET,FRONT FENDER		1	
	28	A130018-43	TAPPING SCREW	5mm×12L	32	

D1033-022

FENDER · SEAT

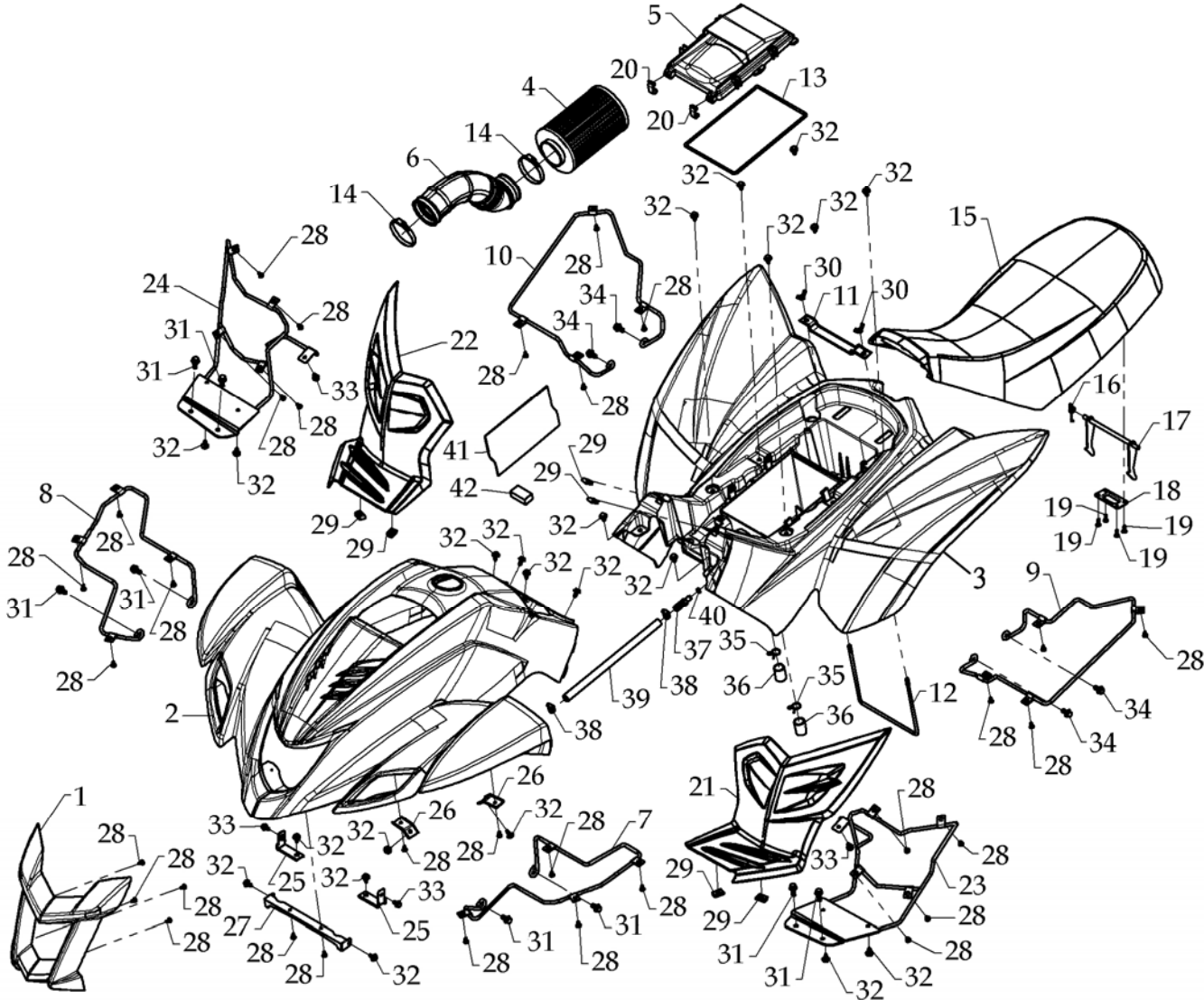

D1033-021

**FENDER 、 SEAT**

<b>Model</b>	<b>Item</b>	<b>Part no</b>	<b>Description</b>	<b>Specification</b>	<b>Q'ty of Usage</b>	<b>Note</b>
	29	F020195-43	NUT CLIP	M6×1.0	6	
	30	A060065-42	WING NUT	M6×1.0	2	
	31	A050049-41	HEXAGONAL FLANGE BOLT	M8×1.25×16L	8	
	32	A050023-41	HEX WASHER FACE BOLT	M6×1.0×16L	22	
	33	A050017-41	HEXAGONAL FLANGE BOLT	M6×1.0×12L	4	
	34	A050024-41	HEXAGONAL FLANGE BOLT	M6×1.0×16L	4	
	35	F150129-00	CLAMP		2	
	36	F150130-00	DRAINAGE COVER		2	
	37	F150126A00	CONNECTOR		1	
	38	F150127-41	CLIP		2	
	39	F150128A01	HOSE	Ø17×Ø12,NBR+PVC	1	
	40	A100015-43	CIRCLIP	Ø10	1	
	41	F140197-00	HEAT INSULATE		1	
	42	F150131-00	ELEMENT		1	

D1033-023

FORNT FRAME

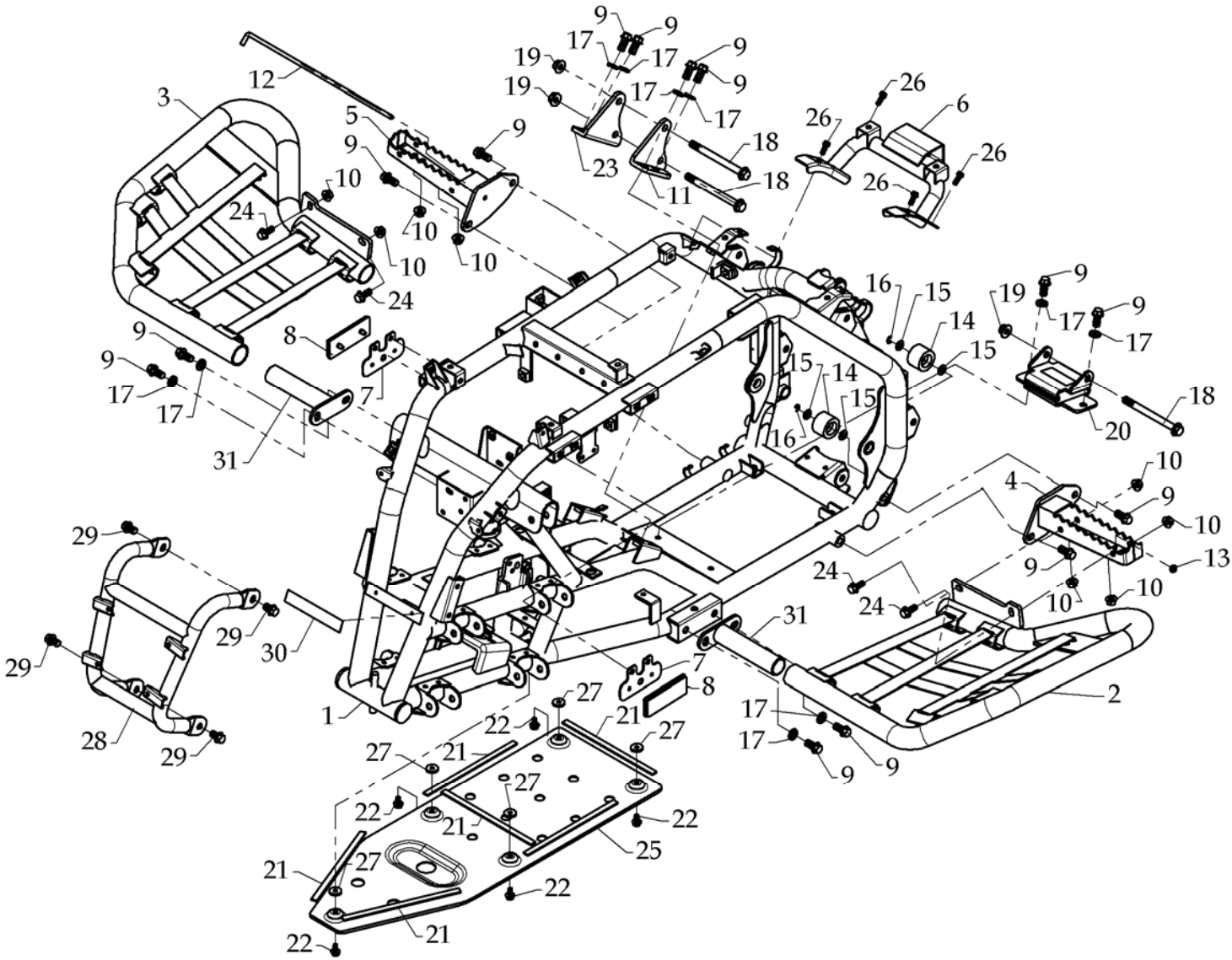

D1033-031

**FORNT FRAME**

<b>Model</b>	<b>Item</b>	<b>Part no</b>	<b>Description</b>	<b>Specification</b>	<b>Q'ty of Usage</b>	<b>Note</b>
	01	F190048K48	FRAME		1	
	02	F150071-98	FOOT PROTECT NET BRACKET	LEFT	1	
	03	F150072-98	FOOT PROTECT NET BRACKET	RIGHT	1	
	04	F150075B48	FOOTREST		1	
	05	F150076B48	FOOTREST		1	
	06	F150168A48	SEAT BRACKET		1	
	07	F150179A50	REFLECTER BRACKET		2	
	08	F020266-00	REFLECTER	YELLOW,CE	2	
	09	A050109-41	HEXAGONAL FLANGE BOLT	M10×1.25×20L	14	
	10	A060014-41	LOCK NUT	M8×1.25	8	
	11	F190045A50	LEFT ENGINE BRACKET		1	
	12	F150160-42	L-TYPE BOLT	M6×1.0	1	
	13	A060053-41	HEX INSERT LOCK NUT	M6×1.0	1	
	14	F150132-00	CHAIN PASSIVE ROLLER		2	
	15	A080095-41	SPACER	Ø8.2×Ø16×1t	4	
	16	A100014-43	E CLIP	Ø6	2	
	17	A080009-41	SPRING WASHER	Ø10.2×3.7×2.5t	10	
	18	A050068A41	HEXAGONAL FLANGE BOLT	M10×1.25×115L	3	
	19	A060007-41	LOCK NUT	M10×1.25	3	
	20	F190044-50	ENGINE DAMPER		1	
	21	F020096-00	DAMPER	EVA	6	
	22	A050017-41	HEXAGONAL FLANGE BOLT	M6×1.0×12L	5	
	23	F190046A50	RIGHT ENGINE BRACKET		1	
	24	A050084-41	HEXAGONAL FLANGE BOLT	M8×1.25×20L	4	
	25	F150162B48	PROTECT PLATE		1	
	26	A050023-41	HEX WASHER FACE BOLT	M6×1.0×16L	4	
	27	A080102-00	RUBBER WASHER	Ø6×Ø19×3t	5	
	28	F200017-48	BRACKET,BUMPER		1	

D1033-032

FORNT FRAME

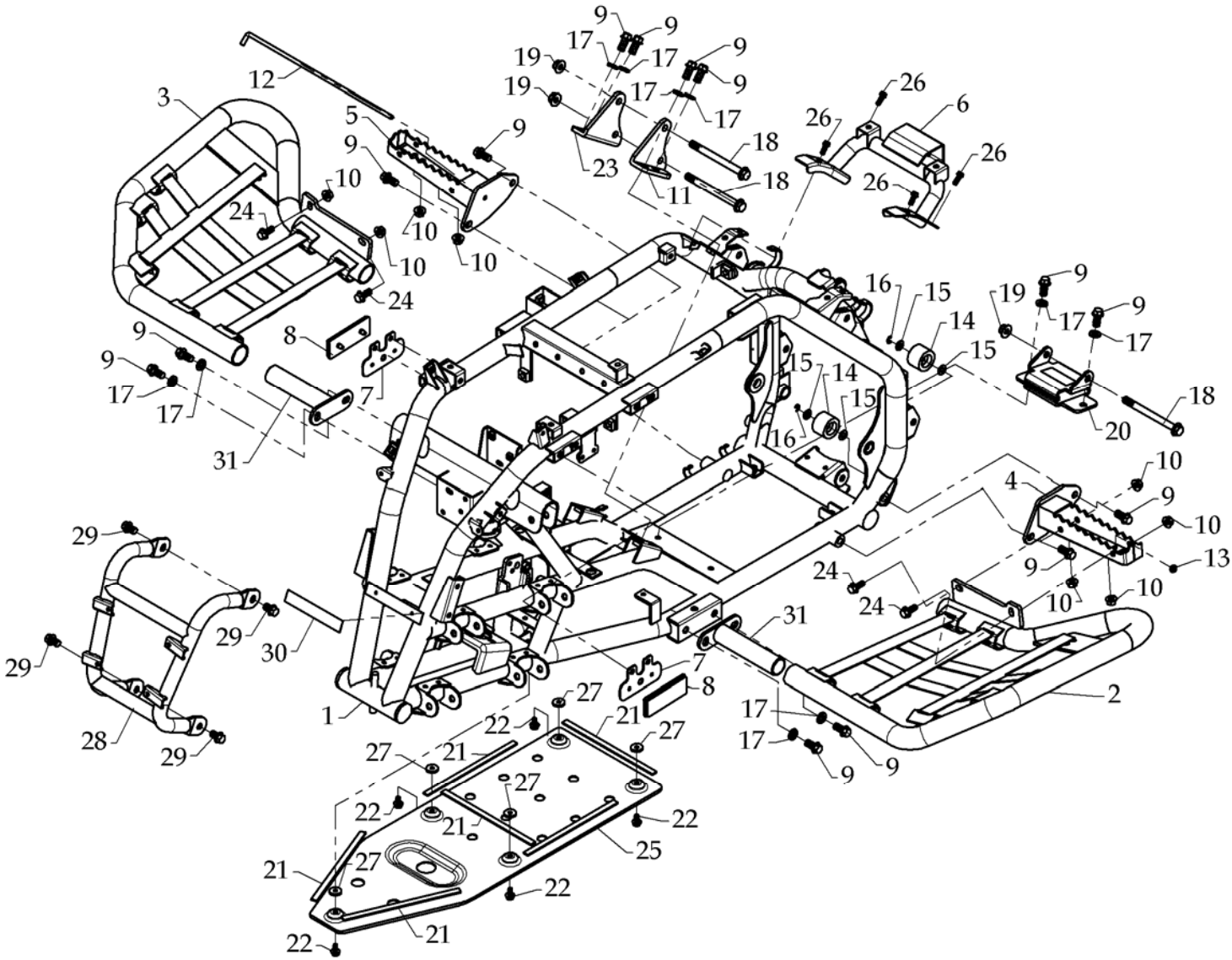

D1033-031

## FORNT FRAME

Model	Item	Part no	Description	Specification	Q'ty of Usage	Note
	29	A050005-41	HEXAGONAL FLANGE BOLT	M10×1.25×15L	4	
	31	F150240-41	BRACKET		2	

D1033-033

REAR FRAME

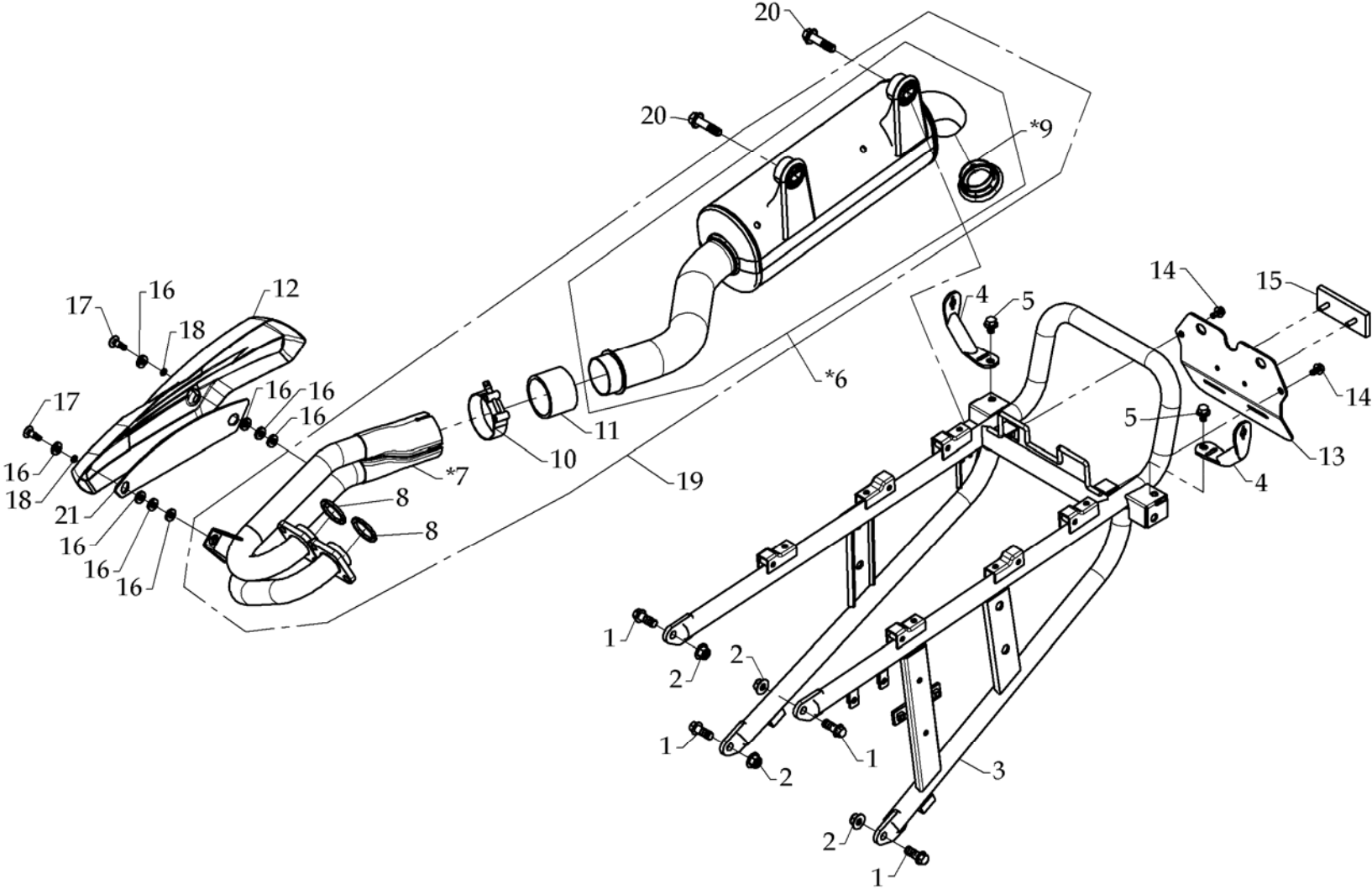

D1033-041

**REAR FRAME**

<b>Model</b>	<b>Item</b>	<b>Part no</b>	<b>Description</b>	<b>Specification</b>	<b>Q'ty of Usage</b>	<b>Note</b>
	01	A050201-41	HEXAGONAL FLANGE BOLT	M10×1.25×25L	4	
	02	A060007-41	LOCK NUT	M10×1.25	4	
	03	F200018-48	SUB FRAME		1	
	04	F150196-50	BRACKET, DIRECTIONAL LIGHT		2	
	05	A050020-41	HEXAGONAL FLANGE BOLT	M8×1.25×12L	2	
	06	F150233-00	MUFFLER	STAINLESS STEEL	1	
	*	F150233-01	MUFFLER		1	
	*	F150233-02	MUFFLER	CATALYST	1	
	07	F150232-00	EXHAUST PIPE	STAINLESS STEEL	1	
	*	F150232-01	EXHAUST PIPE		1	
	08	F150082-00	GASKET CP, EX PIPE		2	
	09	F150237-00	SPARK ARRESTER	STAINLESS STEEL	1	
	*	F150237-01	SPARK ARRESTER		1	
	10	F150180-00	CLAMP	Ø2 1/8"~Ø2 1/6"	1	
	11	F150181-00	GHAPHITE RING	Ø60×Ø51×40L	1	
	12	F150252-00	PROTECTIVE COVER		1	
	13	F200012-50	LICENSE PLATE		1	
	14	A050017-41	HEXAGONAL FLANGE BOLT	M6×1.0×12L	2	
	15	F020265-00	REFLECTER	RED	1	
	16	A080108-01	HEAT INSULATE WASHER	Ø7.8×Ø16×3t	8	
	17	A050245-00	HEXAGONAL SOCKET BOLT	M6×1.0×21L	2	
	18	A040042-00	O RING	P6-Ø1.9×Ø5.8	2	
	19	F150230-98	EXHAUST PIPE ASSY		1	
	20	A050001-41	HEXAGONAL FLANGE BOLT	M10×1.25×40L	2	
	21	F150253-00	HEAT INSULATION PAD		1	

D1033-042

SWING ARM SUB ASS'Y

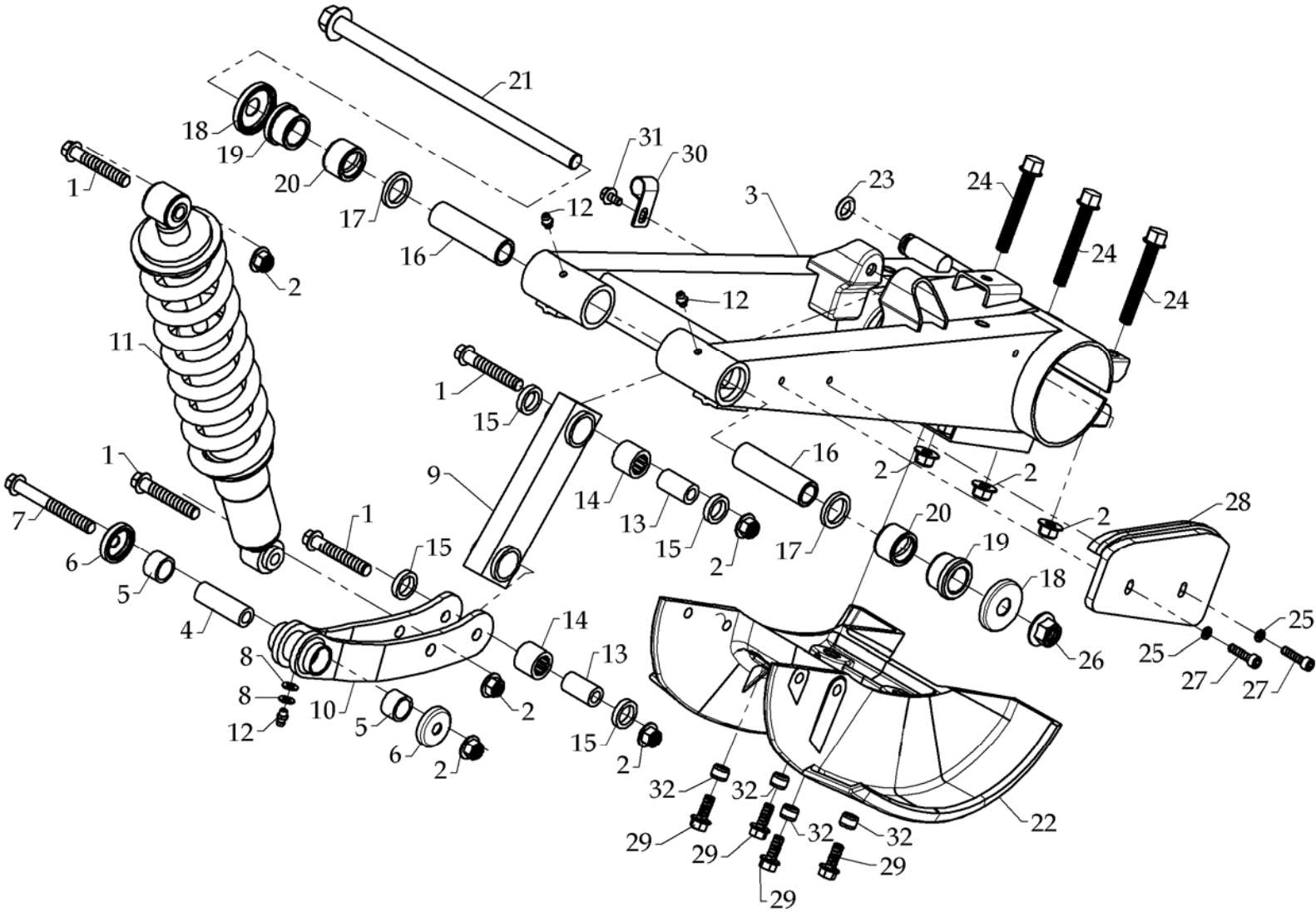

D1033-051

**SWING ARM SUB ASS'Y**

<b>Model</b>	<b>Item</b>	<b>Part no</b>	<b>Description</b>	<b>Specification</b>	<b>Q'ty of Usage</b>	<b>Note</b>
	01	A050230-41	HEXAGONAL FLANGE BOLT	M10×1.25×60L-10T	4	
	02	A060007-41	LOCK NUT	M10×1.25	8	
	03	F150024I48	SWING ARM		1	
	04	A090024B00	SPACER	Ø10×Ø17×51.3L	1	
	05	A020001-00	BUSH		2	
	06	F090041-00	SEAL COVER	C901A4001	2	
	07	A050229-41	HEXAGONAL FLANGE BOLT	M10×1.25×85L-10T	1	
	08	A080036-41	WASHER	Ø6.5×Ø13×1.0	2	
	09	F190050-48	REAR LINKAGE		1	
	10	F150142C48	FRONT LINKAGE		1	
	11	F150043A00	REAR SUSPENSION		1	
	12	F020140-00	GREASE NIPPLE		3	
	13	A090023A00	SPACER	Ø10×Ø17×31L	2	
	14	A010054-00	NEEDLE BEARING	TA1720,Ø24×Ø17×20t	2	
	15	A030033-00	SEAL	VCØ24×Ø17×5t	4	
	16	A090030-00	SPACER	Ø15.5×Ø22×77L	2	
	17	A030030-00	SEAL	TC×4 22×30X4, OS-3704	2	
	18	A030035-00	SEAL COVER	Ø15.5×Ø34.2×Ø44×6.2t	2	
	19	A020008-00	BUSHING		2	
	20	A020009-00	BUSHING	Ø22×Ø30×20L	2	
	21	A050187-41	HEXAGONAL FLANGE BOLT	M14×1.5L×274L	1	
	22	F150109A00	PROTECTOR		1	
	23	A040034-00	O RING	Ø12×4	1	
	24	A050185-41	HEXAGONAL FLANGE BOLT	M10×1.25×70L	3	
	25	A080026-41	WASHER	Ø6.5×Ø19×1.2t	2	
	26	A060006-41	LOCK NUT	M14×1.5	1	
	27	A050029-43	HEX SOCKET BOLT	M6×1.0×25L	2	
	28	F150110-00	CHAIN GUIDE		1	

D1033-052



## SWING ARM SUB ASS'Y

Model	Item	Part no	Description	Specification	Q'ty of Usage	Note
	29	A050084-41	HEXAGONAL FLANGE BOLT	M8×1.25×20L	4	
	30	A220011-00	CLAMP	M6	1	
	31	A050017-43	HEXAGONAL FLANGE BOLT	M6×1.0×12L	1	
	32	A070040-45	DOWEL PIN	Ø13.5×Ø9.8	4	

D1033-053

REAR AXLE

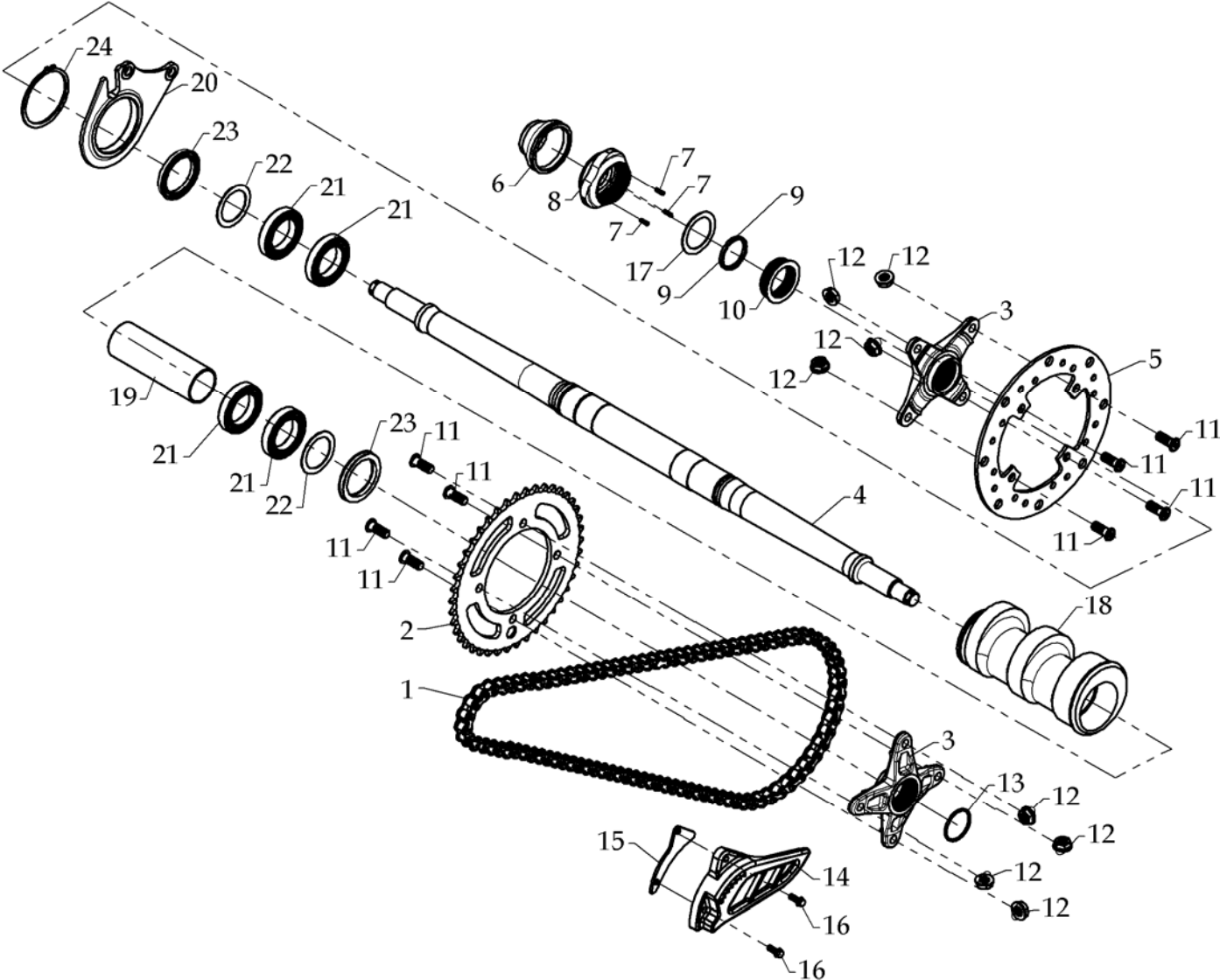

D1033-061

## REAR AXLE

Model	Item	Part no	Description	Specification	Q'ty of Usage	Note
	01	F150041-00	DRIVE CHAIN	520-96 LINKS	1	
	02	F150029-43	SPROCKET	42T×130	1	
	03	F150030A44	HOLDER		2	
	04	F150028A44	REAR AXLE		1	
	05	F150039-01	DISK,BRAKE	Ø220	1	
	06	F150033-00	PROTECT COVER		1	
	07	F150034-43	HEXAGONAL SOCKET BOLT	M4×0.7×12L	3	
	08	F150035-44	REGULATOR NUT		1	
	09	F150036-43	REGULATOR RING		2	
	10	F150037-44	REGULATOR BOLT		1	
	11	A050203A41	SOCKET BOLT	M10×1.25×26L	8	
	12	A060007-41	LOCK NUT	M10×1.25	8	
	13	A100026-41	CIRCLIP		1	
	14	F150107A00	CHAIN COVER		1	
	15	F150148-00	CHAIN COVER BRACKET		1	
	16	A050130-41	HEXAGONAL FLANGE BOLT	M6×1.0×16L	2	
	17	F150038-41	REGULATOR WASHER		1	
	18	F140144-00	ECCENTRIC		1	
	19	F150025-41	SPACER		1	
	20	F150254-50	CALIPER HODER		1	
	21	A010051-04	BEARING,RADIAL BALL	6908LLU,Ø40×Ø62×12t	4	
	22	A040052-00	O RING	Ø36.6×Ø2.5	2	
	23	A030031-00	SEAL	48×62×7 mm	2	
	24	A100022-43	C TYPE CIRCLIP	Ø79.5×Ø64×2.5t	1	

D1033-062

HANDLEBAR

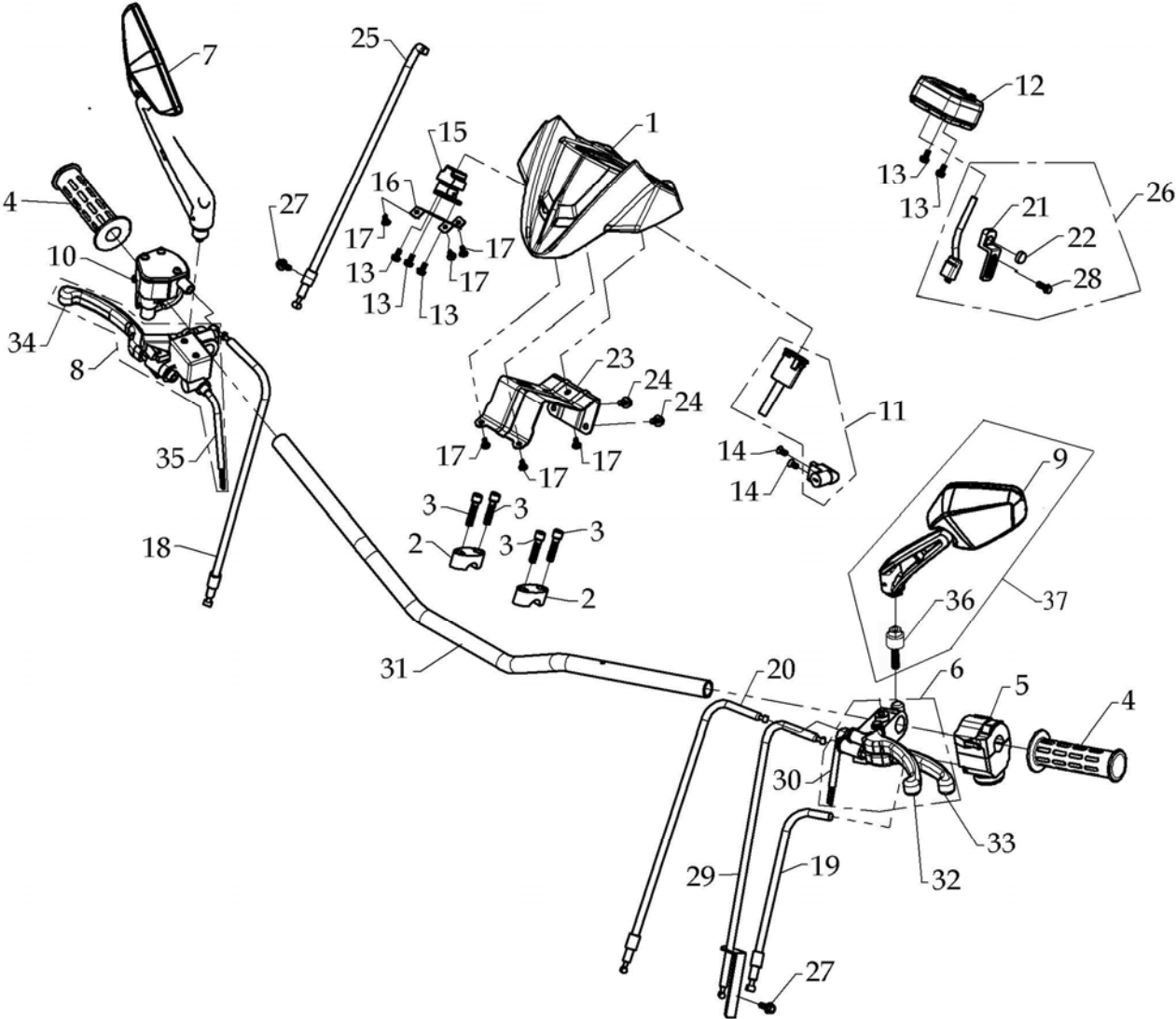

D1033-071

## HANDLEBAR

Model	Item	Part no	Description	Specification	Q'ty of Usage	Note
	01	F200004-98	SPEEDOMETER COVER		1	
	02	F150219-00	UPPER HANDLEBAR CLAMP		2	
	03	A050189-41	HEX SOCKET SCREW	M8×1.25×30L	4	
	04	F020167A00	HANDLE GRIP		2	
	05	A190056-00	LEFT SWITCH ASSY		1	
	06	A190087-00	LEFT LEVER ASSY		1	
	07	A160006-00	REAR-VIEW MIRROR, RIGHT		1	
	08	A190089-00	RIGHT LEVER ASSY	Ø14	1	
	09	A160016-00	REAR-VIEW MIRROR, LEFT		1	
	10	F150161-00	THROTTLE SWITCH	CE	1	
	11	F150105-00	IGNITION SWITCH		1	
	12	F150104A00	SPEEDOMETER	km/mile,DINLI LOGO	1	
	13	A050095-41	PANHEAD SCREW + SPRING WASHER	M5×0.8×12	5	
	14	A050090-41	SOLTTED HEAD BOLT	M6×1.0×12L	2	
	15	F190039A00	REVERSE SWITCH ASSY		1	
	16	F190049-50	BRACKET,REVERSE SWITCH		1	
	17	A130018-43	TAPPING SCREW	5mm×12L	6	
	18	F150063-00	THROTTLE CABLE		1	
	19	F150066-00	CHOKE CABLE		1	
	20	F190062A00	PARKING BRAKE CABLE		1	
	21	F150209-00	BASE,SPEEDOMETER WIRE		1	
	22	F150211-00	MAGNET SENSOR		1	
	23	F140042A48	BRACKET,SPEEDOMETER COVER		1	
	24	A050017-43	HEXAGONAL FLANGE BOLT	M6×1.0×12L	2	
	25	F190040-00	REVERSE CABLE ASSY		1	
	26	F150103-00	WIRE, SPEEDOMETER		1	
	27	A050024-41	HEXAGONAL FLANGE BOLT	M6×1.0×16L	2	
	28	A050023-41	HEXAGONAL BOLT & WASHER	M6×1.0×16L	1	

D1033-072



## HANDLEBAR

Model	Item	Part no	Description	Specification	Q'ty of Usage	Note
	29	F150065-00	CLUTCH CABLE		1	
	30	A190121-00	CLUTCH SENSOR		1	
	31	F150067A50	HANDLEBAR		1	
	32	A190096-00	MANUAL LEVER		1	
	33	A190097-00	MANUAL LEVER		1	
	34	F020268-00	MANUAL LEVER		1	
	35	A190029-00	LIMIT SWITCH		1	
	36	F150255-00	REAR-VIEW MIRROR PARTS		1	
	37	A160017-00	REAR-VIEW MIRROR ASSY			

D1033-073

STEERING

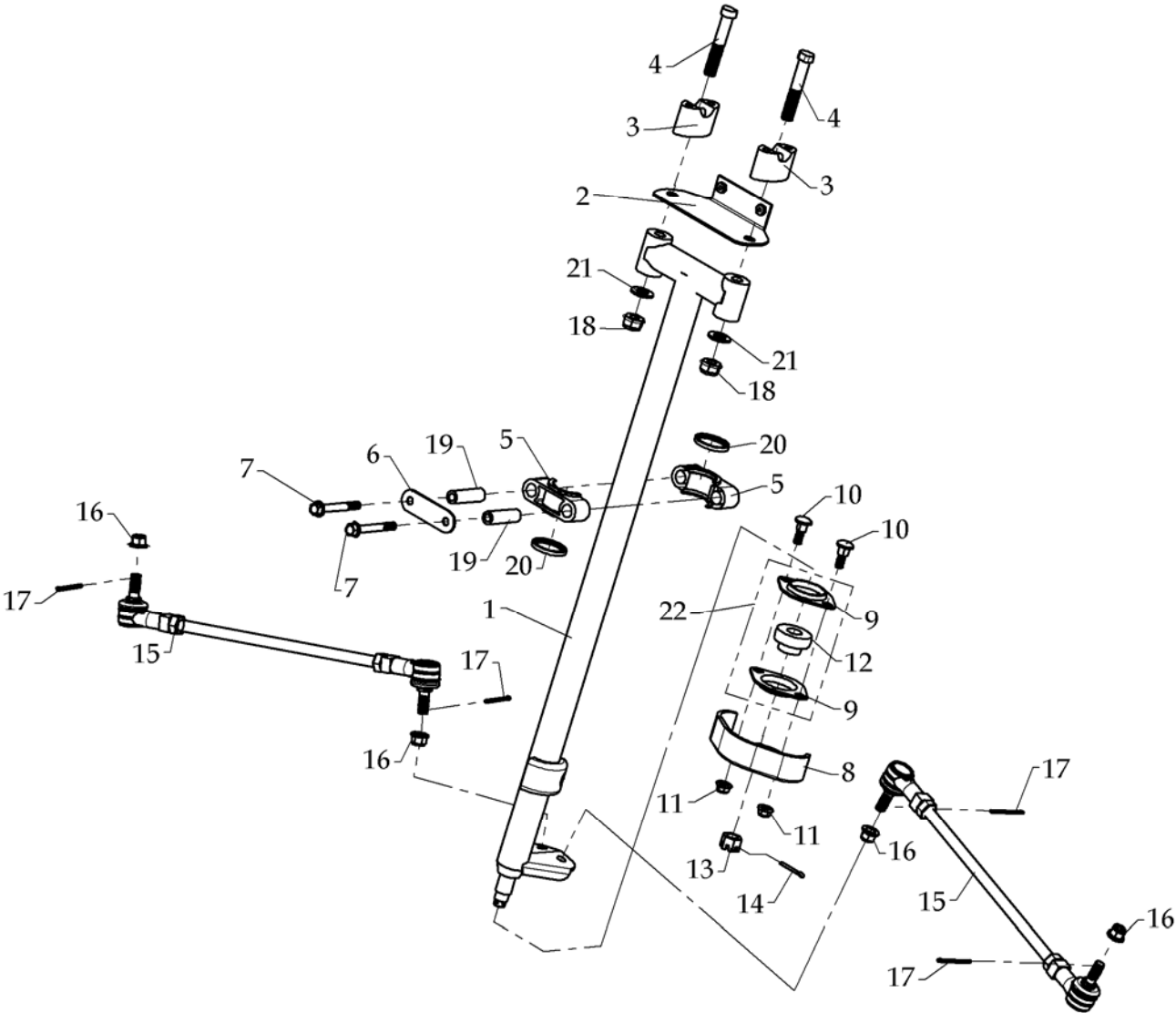

D1033-081

## STEERING

Model	Item	Part no	Description	Specification	Q'ty of Usage	Note
	01	F150047D48	STEERING		1	
	02	F150164A50	BRACKET,SPEEDOMETER COVER		1	
	03	F150220-00	LOWER HANDLEBAR CLAMP		2	
	04	A050228-41	LOCATION BOLT	M12×1.75×70L	2	
	05	F140019-00	STEERING CLAMP		2	
	06	F140082-41	FIXED PLATE		1	
	07	A050010-41	HEXAGONAL FLANGE BOLT	M8×1.25×65L	2	
	08	F150152A48	CHANGE DIRECTION LIMIT		1	
	09	F150049-41	BEARING HOLDING		2	
	10	A050212-41	FLANGE-HEAD BOLT	M8×1.25×25L	2	
	11	A060014-41	LOCK NUT	M8×1.25	2	
	12	A010053-00	BEARING	SB203-17	1	
	13	A060026B42	CADTLE NUT	M14×1.5-II	1	
	14	A070002-41	COTTER PIN	Ø3.2×34.5L	1	
	15	F150206-00	STEERING TIE-ROD ASSY.		2	
	16	A060007-41	LOCK NUT	M10×1.25	4	
	17	A070038-00	COTTER PIN	Ø1.8×Ø10	4	
	18	A060072-41	HEXAGONAL FLANGE BOLT	M12×1.75	2	
	19	F140145-42	SPACER		2	
	20	A030034-00	SEAL COVER		2	
	21	A080106-41	WASHER	Ø13.2×Ø25×2t	2	
	22	F150048-41	BEARING HOLDING ASSY		1	

D1033-082

# FRONT SUSPENSION

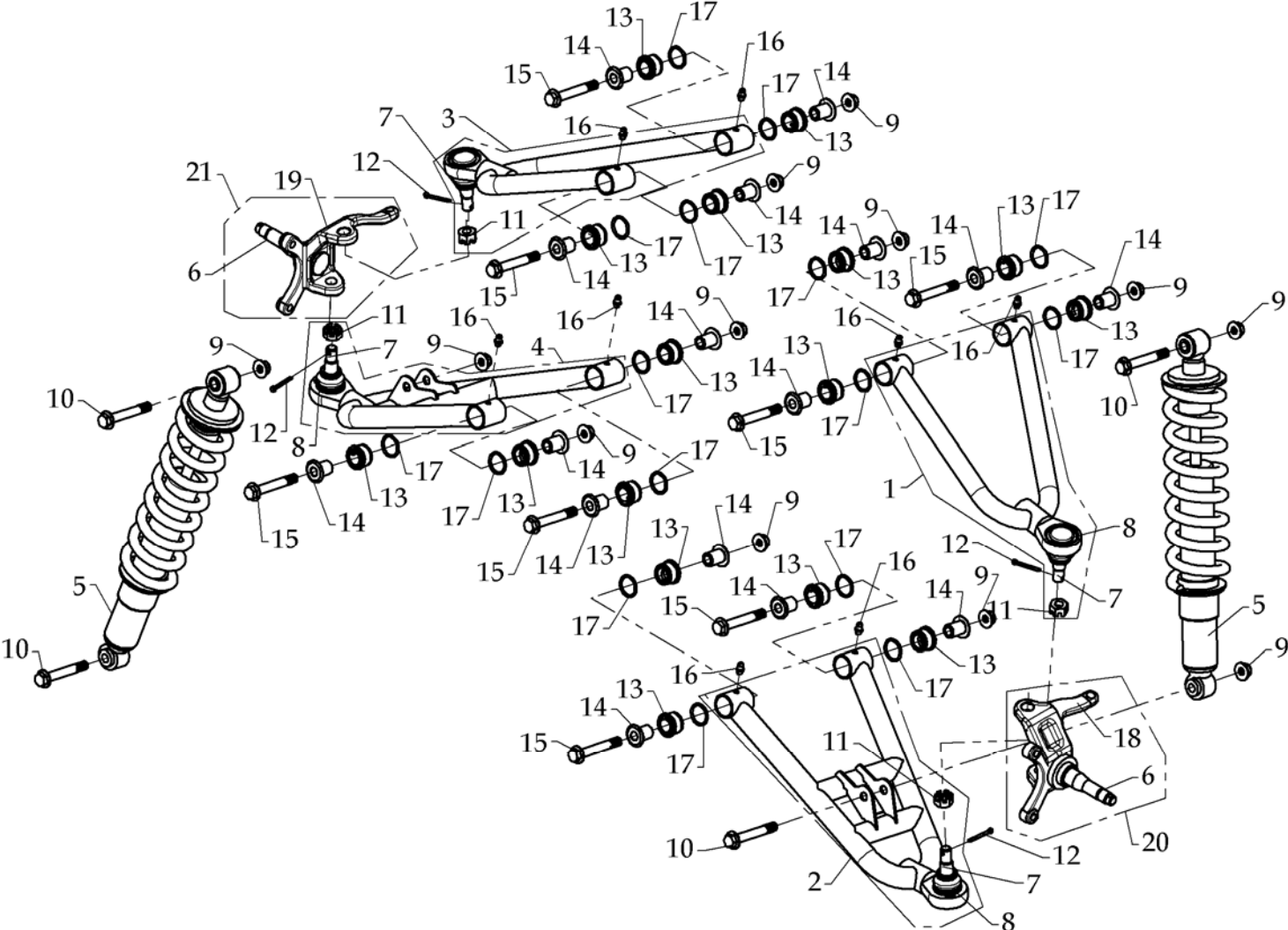

D1033-091

## FRONT SUSPENSIONE

Model	Item	Part no	Description	Specification	Q'ty of Usage	Note
	01	F150014-48	UPPER-LEFT A-ARM		1	
	02	F150012-48	LOWER-LEFT A-ARM		1	
	03	F150015-48	UPPER-RIGHT A-ARM		1	
	04	F150013-48	LOWER-RIGHT A-ARM		1	
	05	F150042-00	FRONT SHOCK ABSORBER		2	
	09	A060007-41	LOCK NUT	M10×1.25	12	
	10	A050213-41	HEXAGONAL FLANGE BOLT	M10×1.25×50L-8T	4	
	11	A060068-41	CASTLE NUT	M12×1.25	4	
	12	A070002-41	COTTER PIN	Ø3.2×34.5L	4	
	13	A090031A00	INTERNAL BUSHING		16	
	14	A090032A43	EXTERIOR BUSHING		16	
	15	A050185-41	HEXAGONAL FLANGE BOLT	M10×1.25×70L	8	
	16	F020140-00	GREESE NIPPLE		8	
	17	A040040-00	O RING	P22(Ø2.4×Ø21.8)	16	
	20	F150019A46	LEFT KNUCKLE ASSY		1	
	21	F150020A46	RIGHT KNUCKLE ASSY		1	

D1033-092

**BRAKE SYSTEM**

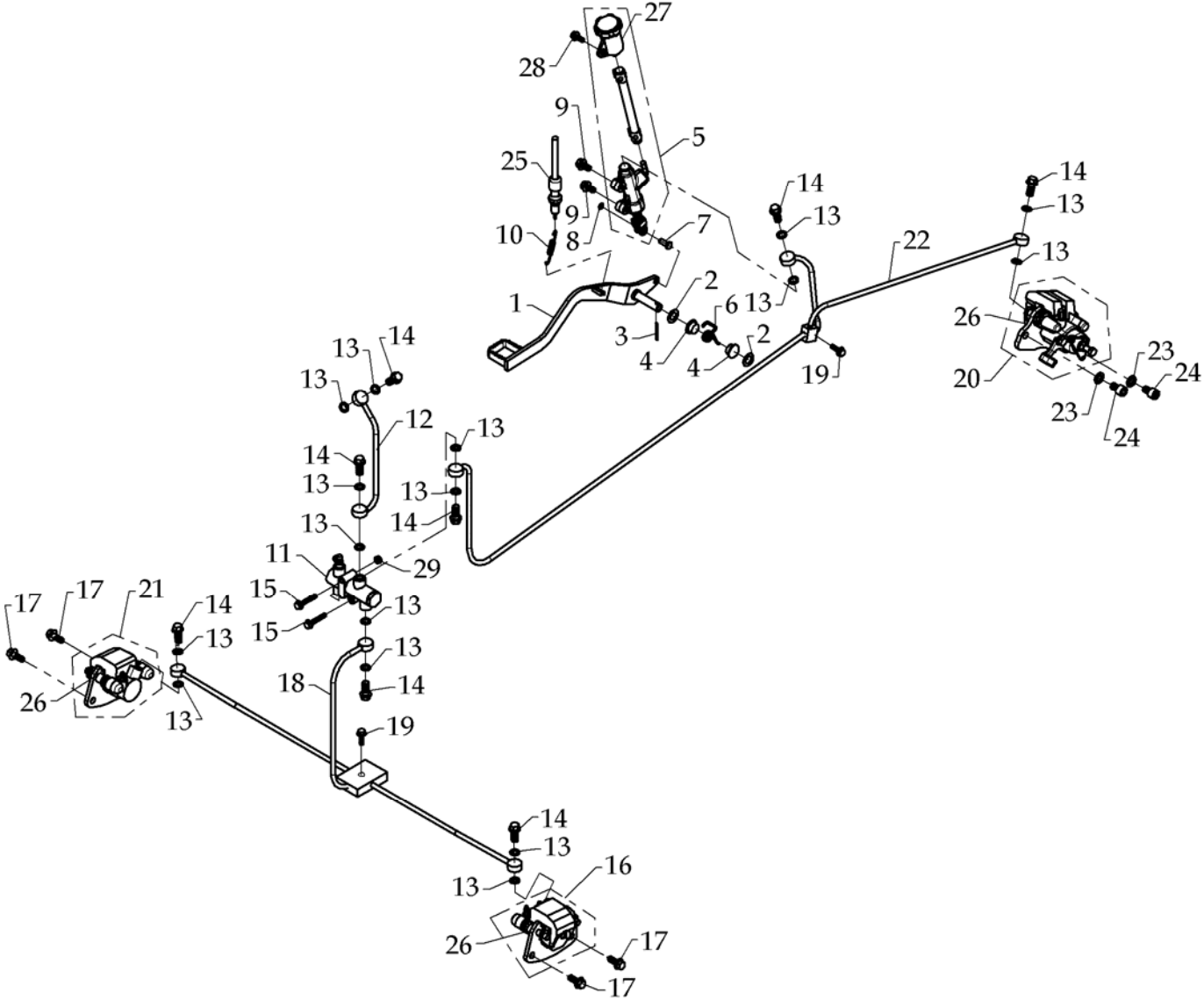

D1033-101

**BRAKE SYSTEM**

Model	Item	Part no	Description	Specification	Q'ty of Usage	Note
	01	F150044B48	BRAKE PEDAL		1	
	02	A080086-41	WASHER	Ø13×Ø22×0.8t	2	
	03	A070011-41	COTTER PIN	Ø2.8×34.5L	1	
	04	F150046-00	BUSHING		2	
	05	F150158-02	BRAKE CYLINDER ASSY		1	
	06	A110035-42	TORSION SPRING		1	
	07	A070021-42	PIN	Ø7×15	1	
	08	A100016-43	E CLIP	Ø5	1	
	09	A050049-41	HEXAGONAL FLANGE BOLT	M8×1.25×16L	2	
	10	A110034-00	TORSION SPRING, BRAKE SENSOR		1	
	11	A220015-00	PRESSURE VALVE	Ø14	1	
	12	F150200-01	BRAKING HOSE		1	
	13	A080011-00	WASHER	Ø10.3×Ø15×1.5	16	
	14	A050009-44	HEXAGONAL FLANGE BOLT	M10×1.25×22L	8	
	15	A050069-41	HEXAGONAL FLANGE BOLT	M6×1.0×40L	2	
	16	F150010-00	FRONT BRAKE CALIPER, LEFT		1	
	17	A050197-41	HEX SOCKET BOLT	M8×1.0×21L	4	
	18	F190056-01	FRONT THREE-WAY BRAKING HOSE		1	
	19	A050030-43	HEXAGONAL FLANGE BOLT	M6×1.0×20L	2	
	20	F190059-00	REAR CALIPER		1	
	21	F150011-00	FRONT BRAKE CALIPER, RIGHT		1	
	22	F190058A01	REAR THREE-WAY BRAKING HOSE		1	
	23	A080082-41	WASHER	Ø10.5×Ø18×2.0t	2	
	24	A050216-41	HEX SOCKET BOLT	M10×1.25×15L	2	
	25	A190054-00	BRAKE SENSOR		1	
	26	F140239-00	PAD,DISK BRAKE		3	
	27	A160008-00	BROKE RESERVOIR		1	
	28	A050024-41	HEXAGONAL FLANGE BOLT	M6×1.0×16L	1	
	29	A060053-41	HEX INSERT LOCK NUT	M6×1.0	1	

D1033-102

COOLING SYSTEM

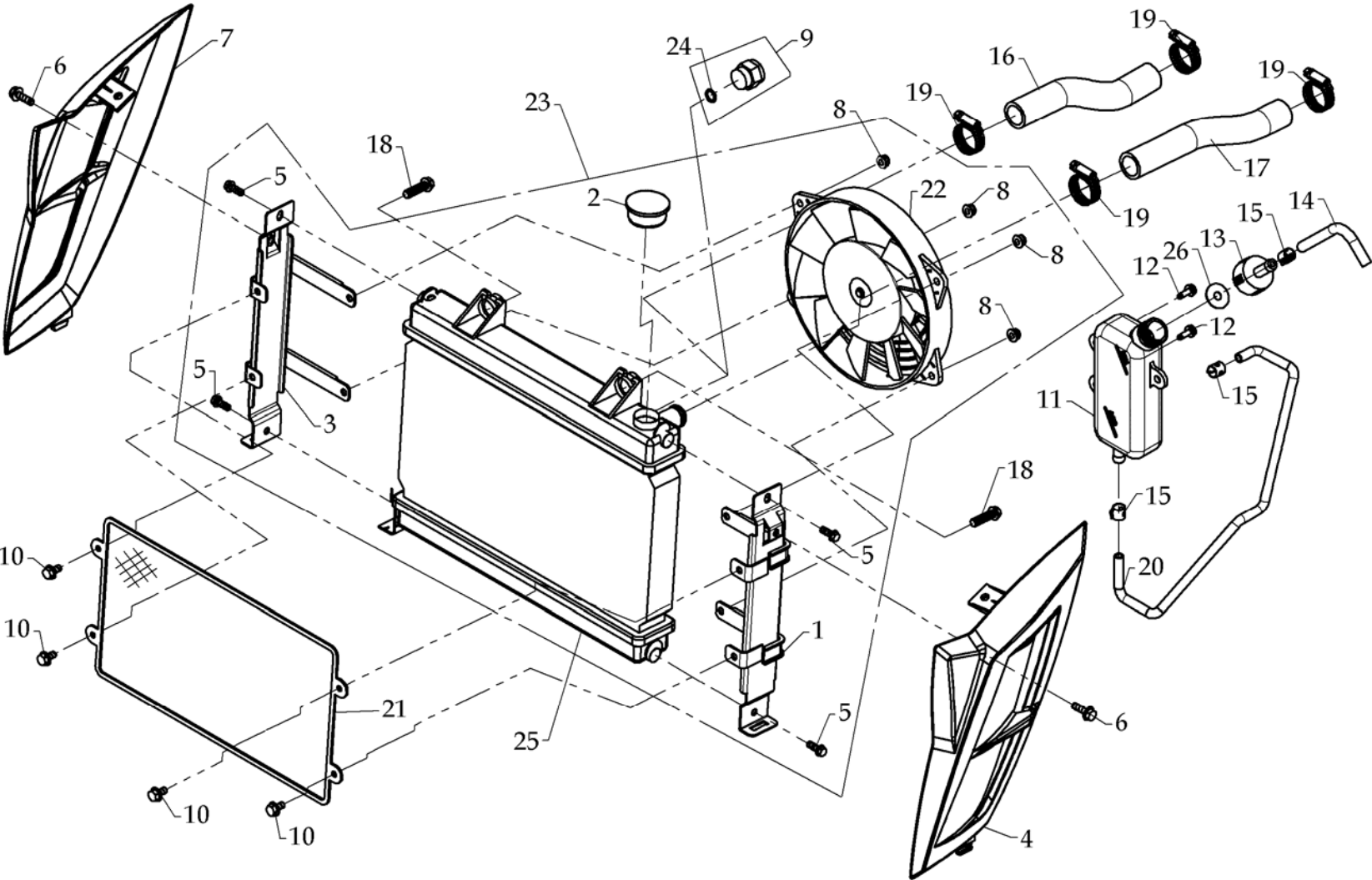

D1033-111

## COOLING SYSTEM

Model	Item	Part no	Description	Specification	Q'ty of Usage	Note
	01	F150188-50	LEFT COVER BRACKET		1	
	02	F150059-00	PRESSURE CAP		1	
	03	F150189-50	RIGHT COVER BRACKET		1	
	04	F150098-98	LEFT COVER,PROTECT		1	
	05	A050023-41	MUFFLER COVER, BOLT	M6×1.0×16L	4	
	06	A050030-43	HEXAGONAL FLANGE BOLT	M6×1.0×20L	2	
	07	F150099-98	RIGHT COVER,PROTECT		1	
	08	A060053-41	HEX INSERT LOCK NUT	M6×1.0	4	
	09	A190099-00	COOLING SENCER	80°C ON×70°C OFF	1	
	10	A050017-43	HEXAGONAL FLANGE BOLT	M6×1.0×12L	4	
	11	F140080-00	COOLANT RESERVOIR		1	
	12	A050156-43	PANHEAD SCREW + SPRING WASHER	M6×1.0×16L	2	
	13	F140087A15	RESERVOIR CAP		1	
	14	F020145-00	HOSE	L=190MM	1	
	15	A220010-00	FUEL TUBE	Ø11×8×0.7t	3	
	16	F150118-00	COOLANT HOSE	Ø12×Ø19×170	1	
	17	F150058-00	COOLANT HOSE	Ø12×Ø19×215	1	
	18	A050186-41	HEXAGONAL FLANGE BOLT	M8×1.25×28L	2	
	19	F150146-00	CLAMP	Ø30~Ø40	4	
	20	A220035-00	HOSE	Ø7×Ø11×520L	1	
	21	F150185-50	RADIATOR PROTECTOR		1	
	22	F170070-00	FAN ASSY		1	
	23	F150167B00	RADIATOR ASSY		1	
	24	A040041-00	O RING	P10-Ø1.9×Ø9.8	1	
	25	F150057A00	RADIATOR		1	
	26	F140223-00	WATER TANK RUBBER		1	

# FUEL TANK

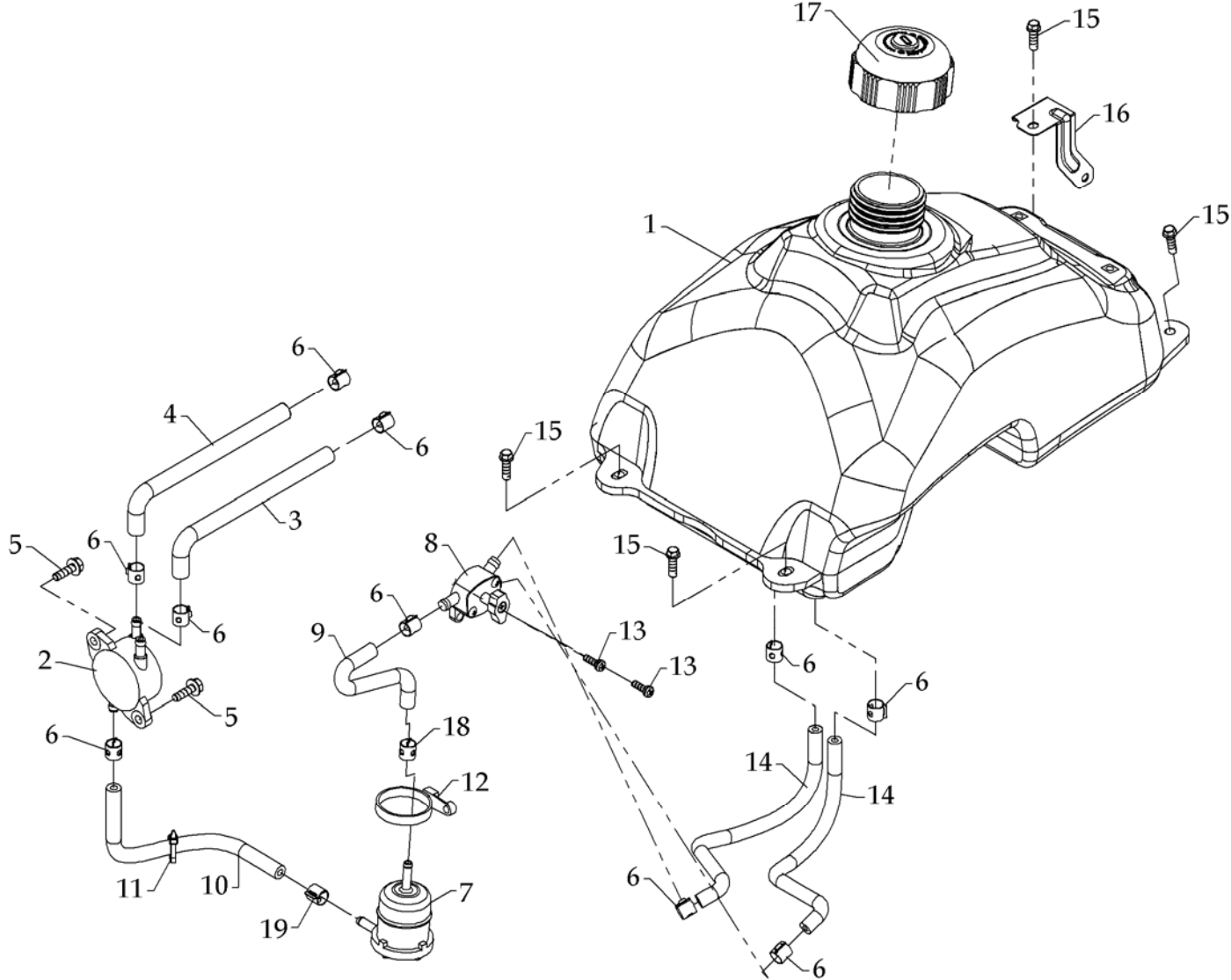

D1033-121

## FUEL TANK

Model	Item	Part no	Description	Specification	Q'ty of Usage	Note
	01	F150212-00	FULE TANK		1	
	02	290-62201-00	FUEL PUMP ASSY		1	
	03	F150114-00	TUBE	Ø6×Ø13×640	1	
	04	F150117-00	TUBE	Ø5×Ø13	1	
	05	A050030-43	HEXAGONAL FLANGE BOLT	M6×1.0×20L	2	
	06	F020196-00	FUEL TUBE	12×0.8	10	
	07	F150223-00	FUEL FILTER ASSEMBLY		1	
	08	A240003-00	FUEL VALVE		1	
	09	A220038-00	TUBE	Ø5.5×Ø10.5	1	
	10	A220026-00	TUBE		1	
	11	F020188-00	STRAP	204L×3.6W	1	
	12	A160007-00	STRAP	TCV-400	1	
	13	A050031-41	PAN HEAD BOLT	M5×0.8×16L	2	
	14	A220039-00	TUBE	Ø8×Ø13X270L	2	
	15	A050063-41	HEX WASHER FACE BOLT	M6×1.0×20L	4	
	16	F150214-48	BRACKET		1	
	17	F140300-00	FUEL TANK CAP		1	
	18	F020197-00	FUEL TUBE	9.2×0.6	1	
	19	A220010-00	FUEL TUBE	Ø11×8×0.7t	1	

D1033-122

OIL TANK

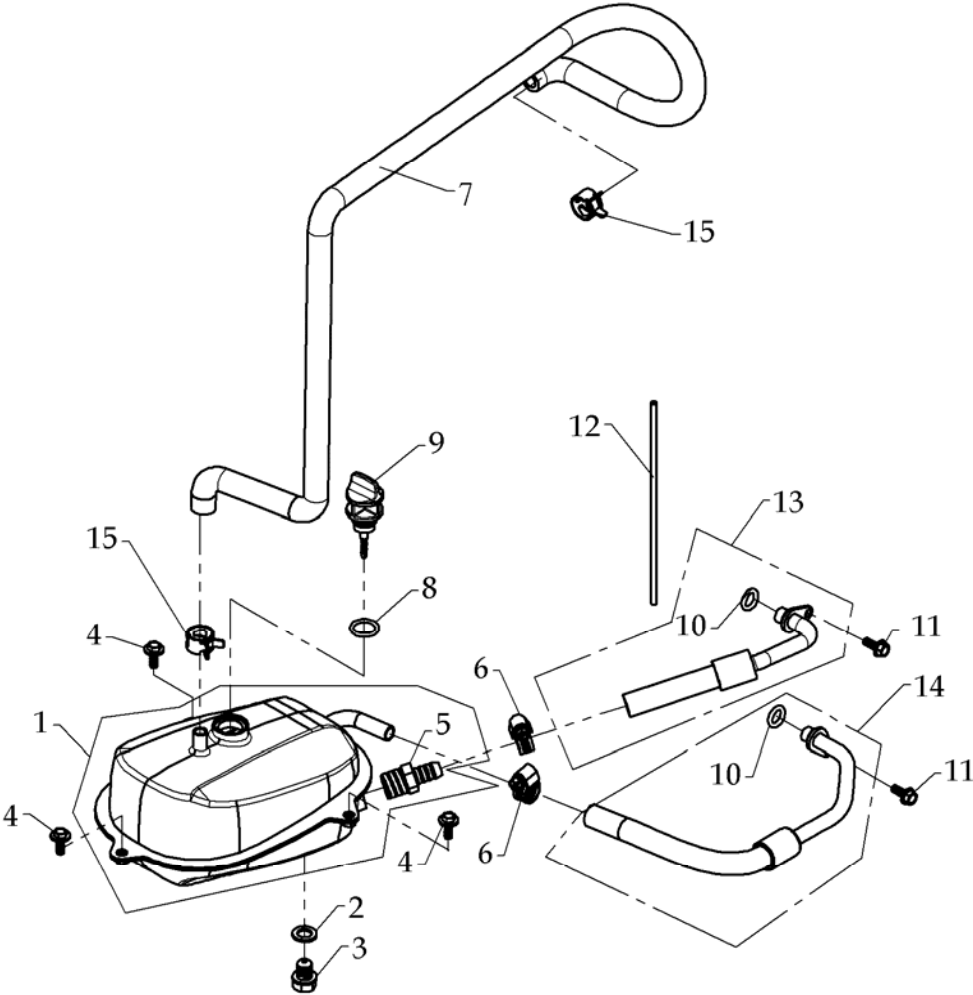

D1033-131

## OIL TANK

Model	Item	Part no	Description	Specification	Q'ty of Usage	Note
	01	F150054-50	OIL TANK		1	
	02	A080052-00	PLAIN WASHER	Ø12.2×Ø20×2.0	1	
	03	A050071-41	DRAINAGE PLUG	M12×1.5×15L	1	
	04	A050022-41	HEX WASHER FACE BOLT	M6×1.0×18L	3	
	05	F150056-00	OIL FILTER		40	1
	06	F150127-41	TUBE CLIP		2	
	07	F150135B00	TUBE	Ø12×Ø17×1230L	1	
	08	A040020-00	O RING	Ø18×3	1	
	09	F150247A00	OIL LEVEL GAUGE		1	
	10	A040027-00	O RING		2	
	11	A050024-41	HEXAGONAL FLANGE BOLT	M6×1.0×16L	2	
	12	F150116-00	TUBE	Ø2.6×Ø5×210	1	
	13	F150136-01	OIL TUBE	Ø12×Ø19	1	
	14	F150213-00	OIL TUBE	Ø12×Ø19	1	
	15	A220020-41	TUBE CLIP	Ø17×12×1.0t	2	

WHEEL

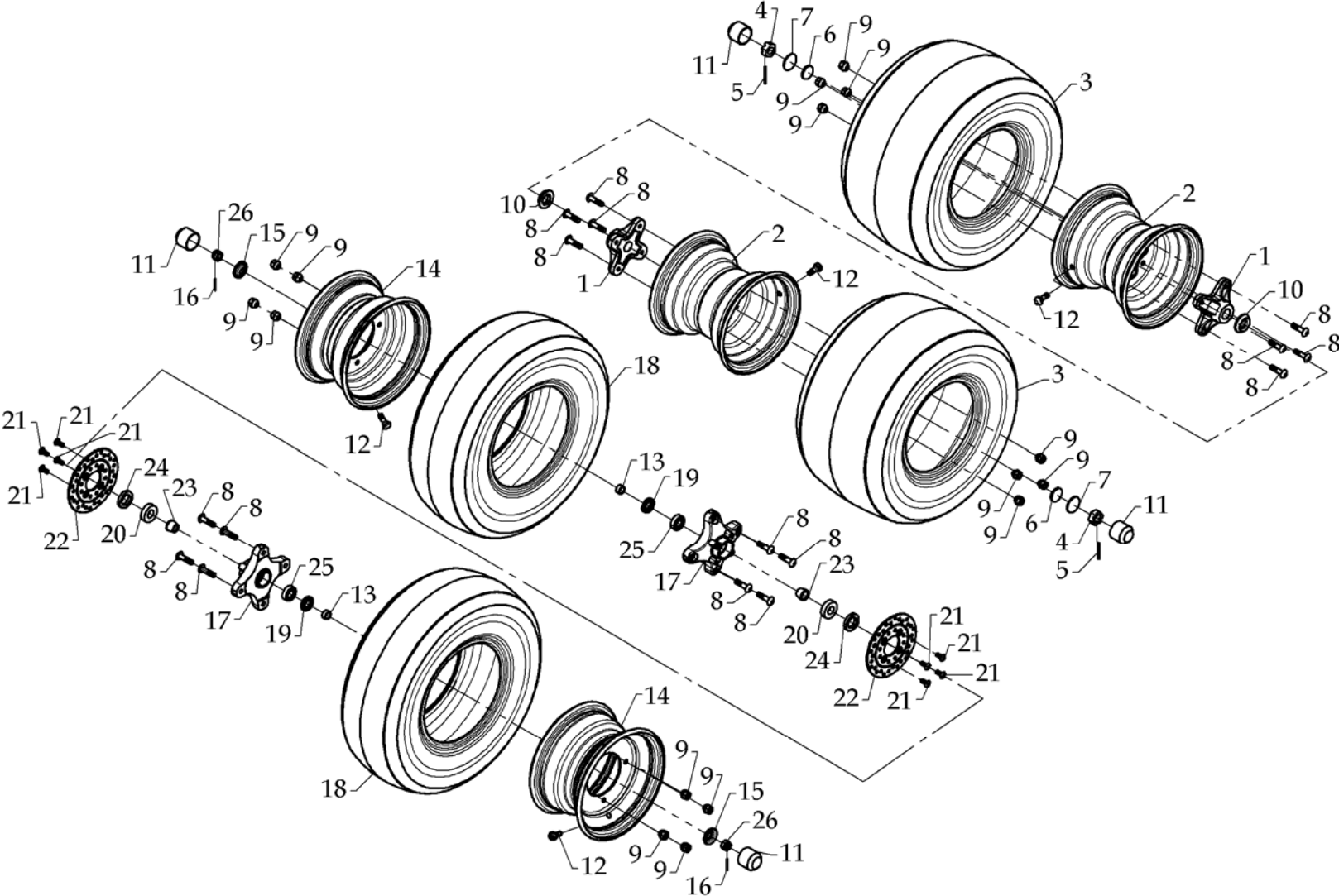

D1033-141

**WHEEL**

<b>Model</b>	<b>Item</b>	<b>Part no</b>	<b>Description</b>	<b>Specification</b>	<b>Q'ty of Usage</b>	<b>Note</b>
	01	F150006-53	SHAFT CONNECTER		2	
	02	F150002-98	RIM	9×8.5	2	
	03	F150009-01	TIRE	20×11-9"	2	
	04	A060058-42	CADTLE NUT	M20×p1.5	2	
	05	A070031-41	COTTER PIN	Ø3.5×45L	2	
	06	A080091-41	WASHER	Ø21×Ø34×4t	2	
	07	A080092-41	WASHER	Ø20.2×Ø40×2.5t	2	
	08	A050208-41	INSERT BOLT	M10×1.25×40L	16	
	09	A060061-41	NUT	M10×1.25	16	
	10	F150032-44	SPACER		2	
	11	F020153-00	RUBBER CAP		4	
	12	F020154-00	RIM VALVE		4	
	13	A090027-45	SPACER	Ø15×Ø20×10.5t	2	
	14	F150001-98	RIM	10×5.5	2	
	15	F020478-42	SEAT, RUBBER CAP		2	
	16	A070002-41	COTTER PIN	Ø3.2×34.5L	2	
	17	F150005A53	SHAFT CONNECTER		2	
	18	F150008-01	FRONT WHEEL	21×7-10"	2	
	19	A030016-00	SEAL	TC 20×35×7	2	
	20	A010025-04	SEALED BEARING	6004LLU	2	
	21	A050183-41	FHSC	M8×1.25×17L	8	
	22	F150003A00	DISK,BRAKE		2	
	23	F150004-41	SPACER		2	
	24	A030029-00	SEAL	TC 28×42×7t	2	
	25	A010021-04	SEALED BEARING	6202LLU	2	
	26	A060004-42	CASTLE NUT	M14×1.5-II	2	
			HEX INSERT LOCK NUT			

**ELECTRIC SYSTEM**

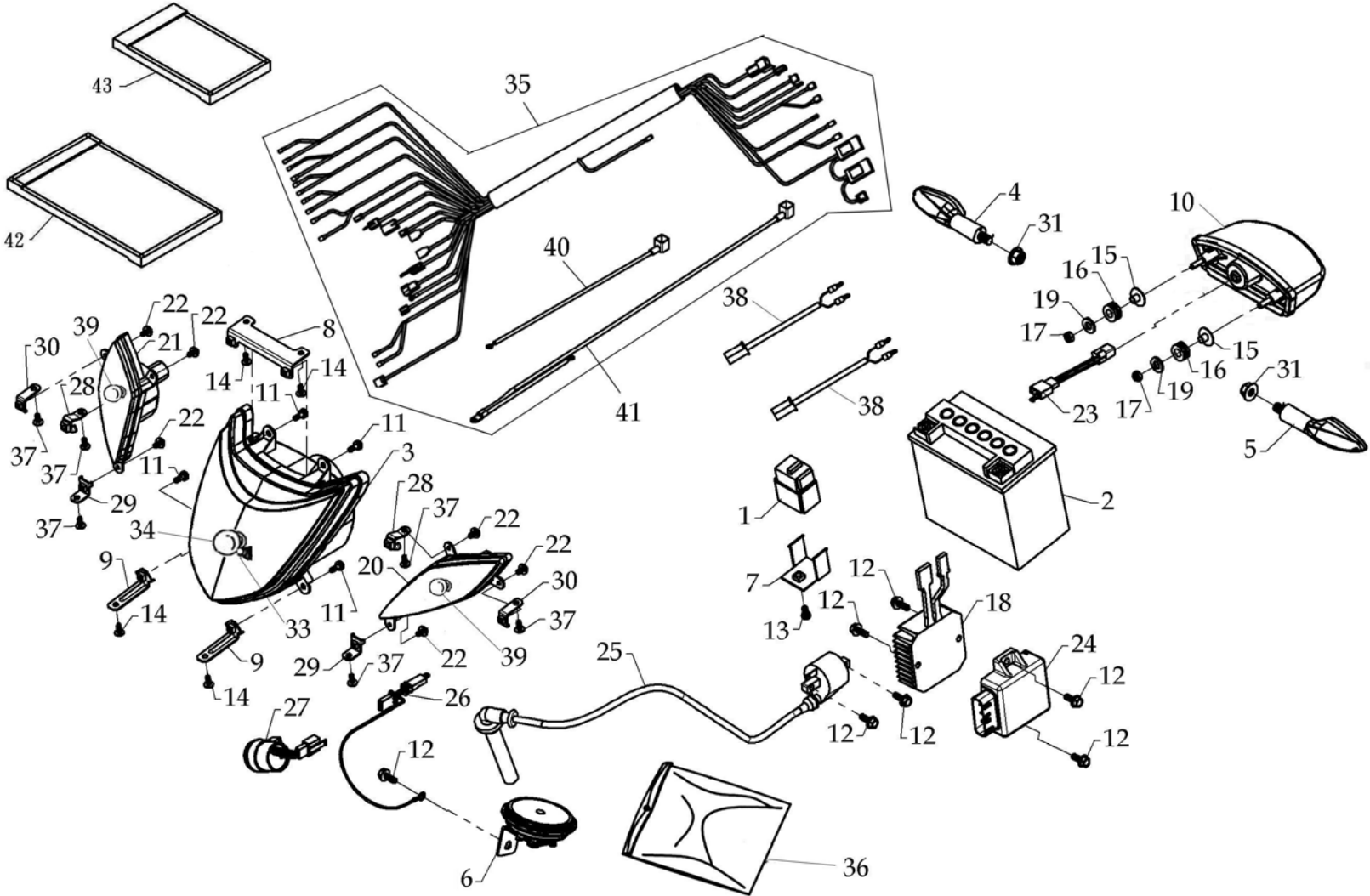

D1033-151

## ELECTRIC SYSTEM

Model	Item	Part no	Description	Specification	Q'ty of Usage	Note
	01	A190061-00	STARTER RELAY		1	
	02	A190062-00	BATTERY	14Ah	1	
	03	A180080A00	HEAD LIGHT		1	
	04	A180079-00	DIRECTIONAL SIGNAL	350L	1	
	05	A180078-00	DIRECTIONAL SIGNAL	250L	1	
	06	A190133-00	HORN		1	
	07	F170042-50	BRACKET,STARTER RELAY	ED	1	
	08	A230079-50	BRACKET,HEAD LIGHT		1	
	09	A230080-50	BRACKET,HEAD LIGHT		2	
	10	A180077-00	TAIL LIGHT	LED	1	
	11	A050100-43	PANHEAD SCREW + WASHER	M5×0.8×15L	4	
	12	A050024-41	HEXAGONAL FLANGE BOLT	M6×1.0×16L	7	
	13	A050043-41	PANHEAD SCREW	M6×1.0×12L	1	
	14	A130018-43	TAPPING SCREW	5mm×12L	4	
	15	F140079-42	T TYPE BUSH		2	
	16	F140156-00	DAMPER		2	
	17	A060053-41	HEX INSERT LOCK NUT	M6×1.0	2	
	18	A190088-00	REGULATION	270W	1	
	19	A080068-41	WASHER	Ø9×Ø18×2t	2	
	20	A180028-02	FRONT TURN SIGNAL	FR\RR	1	
	21	A180029-02	FRONT TURN SIGNAL	FR\RL	1	
	22	A050159-41	PANHEAD SCREW + WASHER	M5×0.8×10L	6	
	23	A180067-00	CABLE,TAILLIGHT	903 3PIN/4PIN	1	
	24		CDI	see engine parts manual	1	
	25		IGNITION COIL	see engine parts manual	1	
	26	A180066-00	RELAY CONNECTOR CABLE		1	
	27	A190092-00	FLASH RELAY	LED	1	
	28	A230074-50	BRACKET, DIRECTIONAL LIGHT		2	

# ELECTRIC SYSTEM

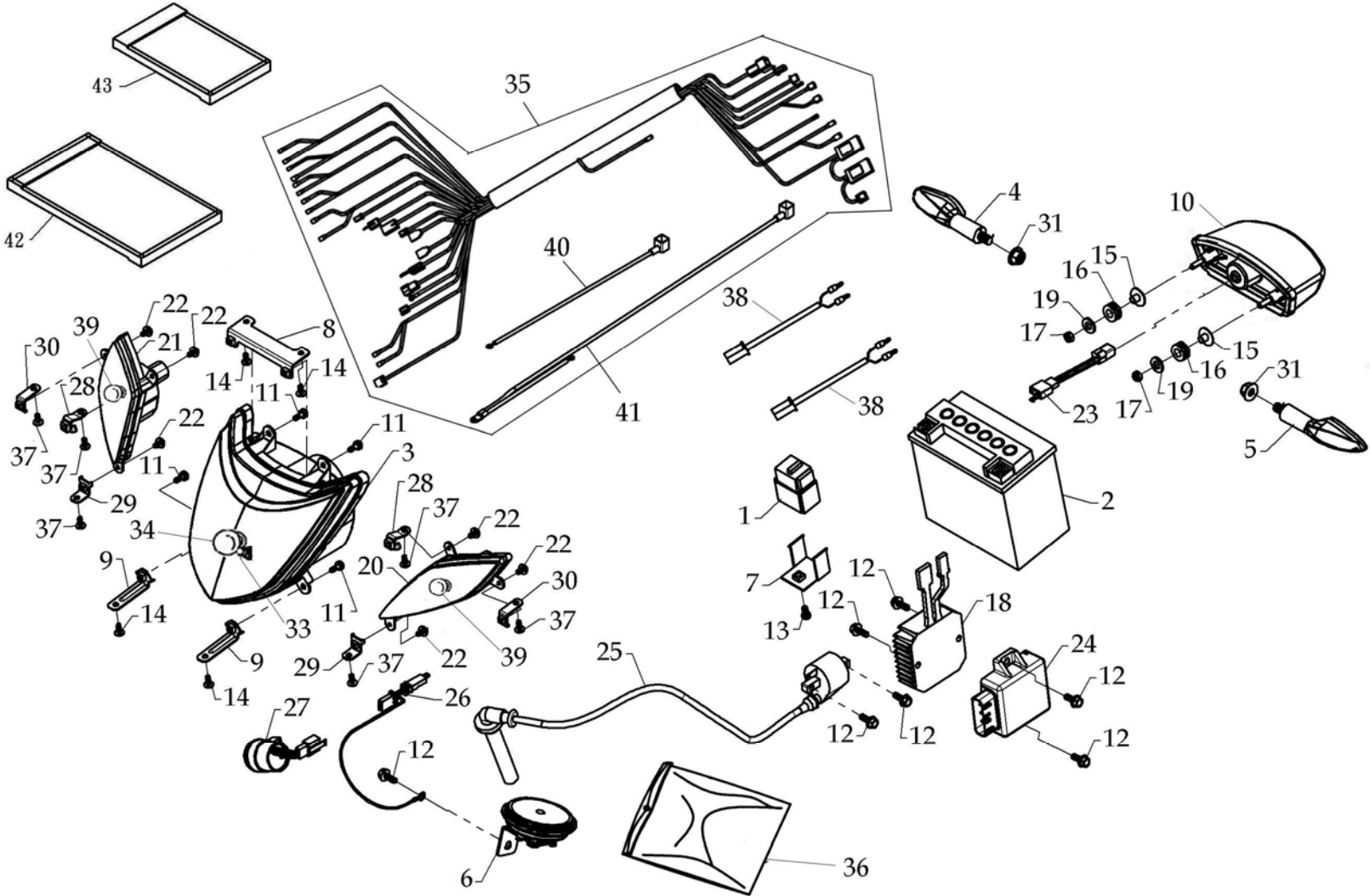

D1033-151

## ELECTRIC SYSTEM

Model	Item	Part no	Description	Specification	Q'ty of Usage	Note
	29	A230075-50	BRACKET, DIRECTIONAL LIGHT		2	
	30	A230076-50	BRACKET, DIRECTIONAL LIGHT		2	
	31	A060010-41	HEXAGONAL FLANGE NUT	M10×1.25	2	
	32					
	33	A180049-00	BULB	12V-5W,CE	1	
	34	A180055-00	BULB	12V-35/35W HS1(E-Mark	1	
	35	F150102A00	MAIN CABLE ASSY'		1	
	36	F150155-00	TOOL KIT		1	
	37	A050096-41	PANHEAD SCREW	M4×0.7×12L	6	
	38	A180064-00	DIRECTIONAL LIGHT CABLE		2	
	39	A180083-00	BULB	12V/10W,YELLOW	2	
	40	F150238-00	LEAD,STARTER MOTOR		1	
	41	F150239-00	WIRE,NOGETIVE POLE		1	
	42	F040097-00	JACKET		1	
	43	A930005-00	STRAP	120×200	1	

# STICKERS



3



2



1

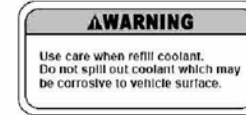

4

## STICKERS

Model	Item	Part no	Description	Specification	Q'ty of Usage	Note
	01	A990246-98	STYLING STICKERS		1	
	02	A990234-00	STICKER, TIRE PRESSURE		1	
	03	A990214-00	STICKER, WARNING SIGN		1	
	04	A990210-00	STICKER, RESERVOIR		1	

D1033-162

**COOLING WATER**

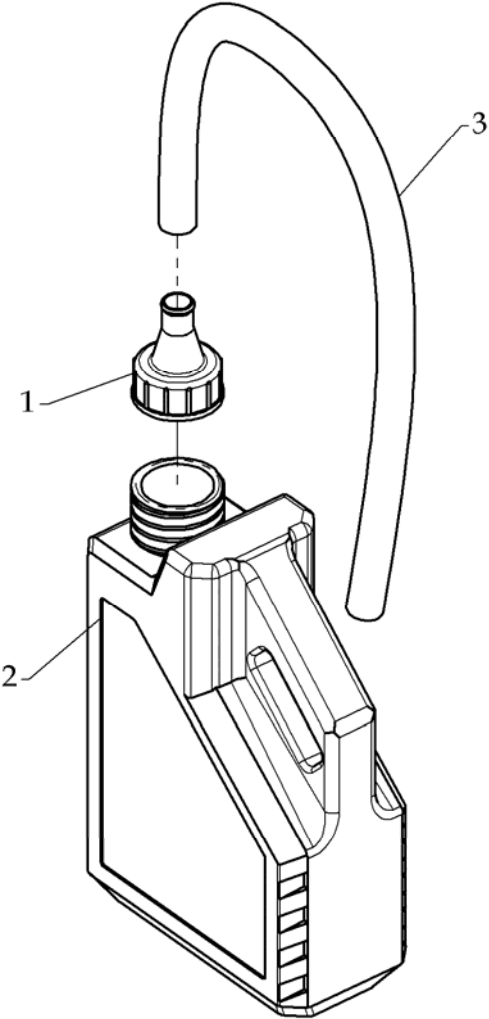

D1033-171

## COOLING WATER

Model	Item	Part no	Description	Specification	Q'ty of Usage	Note
	01	F140262-00	FULL CAP		1	
	02	F150203-00	COOLING WATER	2L	1	
	03	F140264-00	TUBE	Ø15×Ø18×680L	1	

D1033-172